



EFL201

2000kg 4-wheel Li-ion Counterbalance Forklift



- 80 V Li-Ion battery forklift truck designed around I/C implemented chassis
- High ground clearance and big tires for perfect handling and traction in every environment
- Great ergonomic design with spacious legroom, adjustable steering wheel and comfortable bucket seat
- Simple layout with easy access to the main components for practical maintenance
- New mast with unimpeded view ensuring operation safety
- Wide selection of Li-Ion battery and charger to meet wide range of applications



Manufacturer			EP
Model designation			EFL201
Drive			Electric
Load capacity	Q	kg	2000
Load center distance	c	mm	500
Service weight		kg	2975
Height, mast lowered	h1	mm	2020
Lift height	h3	mm	3000
Height, mast extended	h4	mm	4028
Length to face of forks	l2	mm	2240
Overall width	b1/b2	mm	1080
Fork dimensions	s/e/l	mm	40x122x1070
Turning radius	Wa	mm	2078
Travel speed, laden/unladen		km/h	11/14
Lifting speed, laden/unladen		m/s	0.25/0.3
Lowering speed, laden/unladen		m/s	0.43/0.45
Max. gradeability, laden/unladen		%	12/15
Drive motor rating S2 60 min		kW	6
Battery voltage/nominal capacity		V/Ah	80/150

FEATURE

80V Li-ion battery offering powerful performance

The EFL201 adopts EP's in-house 80V/150Ah lithium-ion battery and 80V/35A integrated charger as standard, giving operators the benefit of fast and opportunity charging, zero emission and zero maintenance. Besides, the 80 voltage motor offers higher power efficiency than regular 48 voltage motor, delivering great productivity and performance.



Newly designed mast for better visibility

The mast is newly designed with fewer oil tubes in the line of sight. Operators can easily see fork tips, load and the surrounding area at all times and transport goods safely.



Ergonomic strengths for operation comfort

The EFL201 is designed with great ergonomics in mind. The accelerator pedal is moved forward by 40mm to provide more legroom. Combined with the adjustable steering wheel and comfortable seat, operators therefore enjoy fatigue-free work and improve handling capacities.



High ground clearance and water resistance

The EFL201 comes with high ground clearance of 120mm and solid rubber tyres, which enables use on uneven surfaces. Its water-protected design can also withstand all weather conditions and makes it easy to transport goods outdoors.



Electric Counterbalance Forklift Truck 2.0T EFL201

Distinguishing mark	1.1	Manufacturer			EP
	1.2	Model designation			EFL201
	1.3	Drive unit			Electric
	1.4	Operator type			Seated
	1.5	rated capacity	Q	kg	2000
	1.6	Load center distance	c	mm	500
	1.8	Load distance, centre of drive axle to fork	x	mm	465.5
	1.9	Wheelbase	y	mm	1448
	Service weight	2.1	Service weight		kg
2.2		Axle loading, laden front/rear		kg	4610/365
2.3		Axle loading, unladen front/rear		kg	1270/1705
Tyres/chassis	3.1	Tyre type			Solid rubber
	3.2	Tyre size, front			6.5-10
	3.3	Tyre size, rear			5.00-8
	3.5	Wheels, number front/rear (x=drive wheels)		mm	2x/ 2
	3.6	Tread, front	b10	mm	905
	3.7	Tread, rear	b11	mm	920
	Dimensions	4.1	Tilt of mast/fork carriage forward/backward	α/β	°
4.2		Height, mast lowered	h1	mm	2020
4.3		Free lift	h2	mm	100
4.4		Lift height	h3	mm	3000
4.5		Height, mast extended	h4	mm	4028
4.7		Height of overhead/ guard cabin	h6	mm	2080
4.8		Seat height/standing height	h7	mm	1060
4.12		Tow coupling height	h10	mm	370
4.19		Overall length	l1	mm	3314
4.20		Length to face of forks	l2	mm	2240
4.21		Overall width	b1/b2	mm	1080
4.22		Fork dimensions	s/e/l	mm	40x122x1070
4.23		A,B Fork carriage class/type A, B			2A
4.24		Fork carriage width	b3	mm	1040
4.31		Ground clearance, laden, below mast	m1	mm	115
4.32		Ground clearance, center of wheelbase	m2	mm	120
4.34.1		Aisle width for pallets 1000x1200 crossways	Ast	mm	3743.5
4.34.2	Aisle width for pallets 800x1200 crossways	Ast	mm	3943.5	
4.35	turning radius	Wa	mm	2078	
Performance data	5.1	Travel speed, laden/unladen		km/h	11/14
	5.2	Lifting speed, laden/unladen		m/s	0.25/ 0.3
	5.3	Lowering speed, laden/unladen		m/s	0.43/ 0.45
	5.5	Drawbar pull, laden/unladen		N	—
	5.6	Max. drawbar pull, laden/unladen		N	10000
	5.8	Max. gradeability, laden/unladen		%	12/15
	5.10	Service brake			Hydraulic
5.11	Parking brake			Mechanical	
Electric-engine	6.1	Drive motor rating S2 60 min		kW	6
	6.2	Lift motor rating at S3 15%		kW	11
	6.4	Battery voltage/nominal capacity		V/Ah	80/150
	6.5	Battery weight		kg	—
Addition data	8.1	Type of drive unit			AC
	10.5	Steering design			Hydraulic
	10.7	Sound pressure level at the driver's ear		dB(A)	70

If there are improvements of technical parameters or configurations, no further notice will be given.
The diagram shown may contain non-standard configurations.

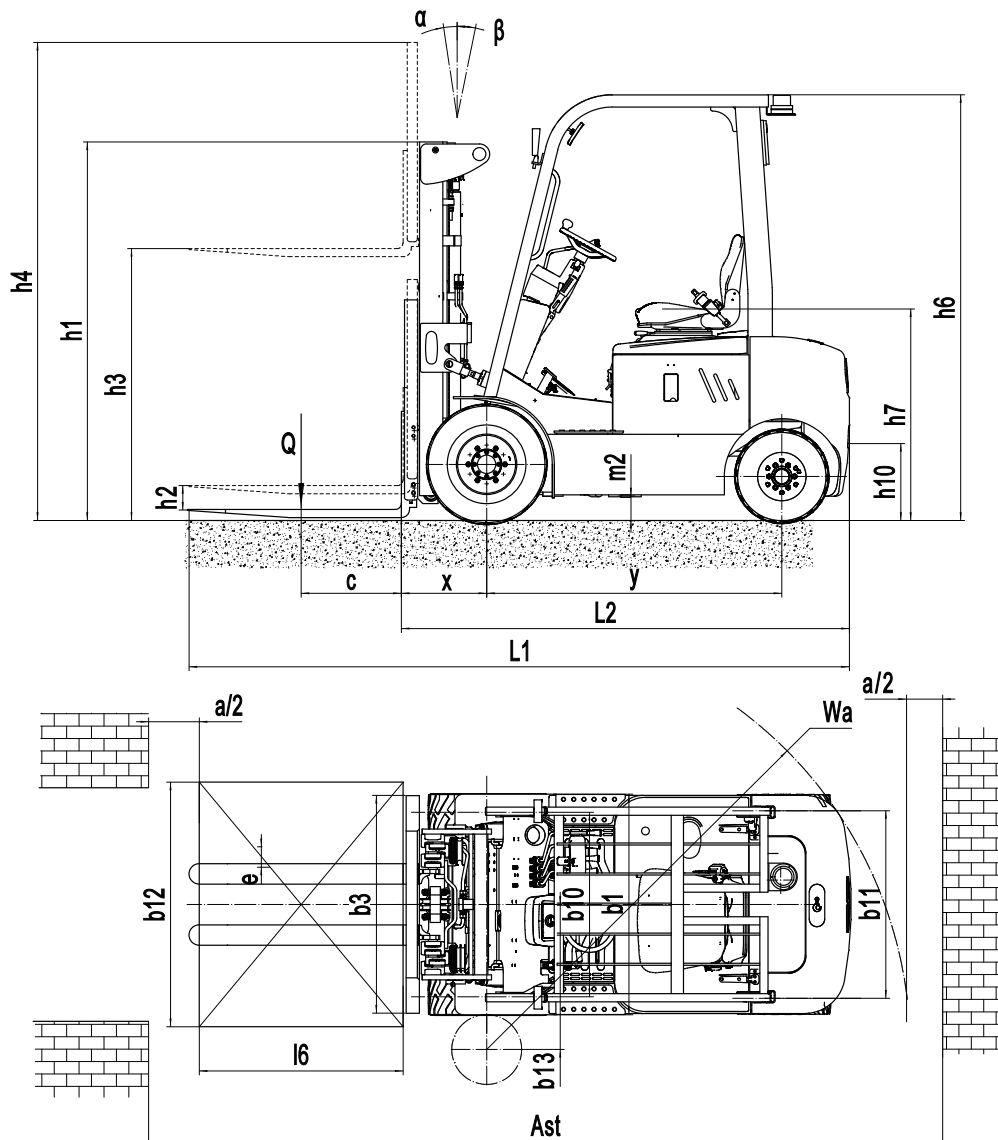

Mast Option

Mast types	Lift height (h_3)	Height, Mast			Height, Free lift(h_2)	
		Height, mast lowered(h_1)	Height, mast extended(h_4)		No shelving	With shelving
			No shelving	With shelving		
	mm	mm	mm	mm	mm	mm
2-Standard Mast	2500	1770	3185	3528	100	100
	2700	1870	3385	3728	100	100
	3000	2020	3685	4028	100	100
	3300	2170	3985	4328	100	100
	3500	2270	4185	4528	100	100
	3600	2320	4285	4628	100	100
3-Free Mast	4350	2035	5074	5378	1196	892
	4500	2085	5224	5528	1246	942
	4800	2185	5524	5828	1346	1042
	5000	2250	5724	6028	1411	1107

RATED CAPACITIES AND LOAD CENTERS GRAPH

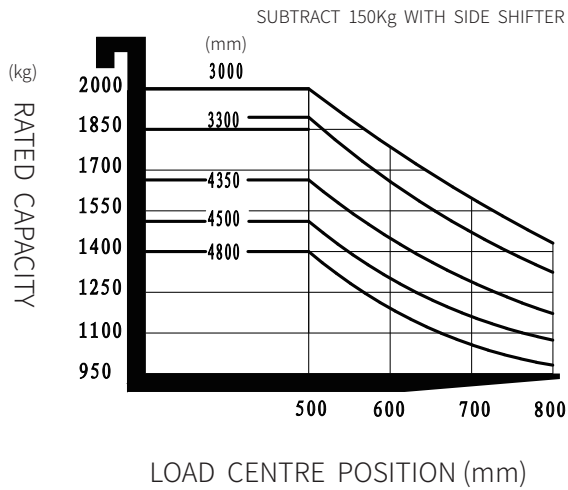

Option

No.	Optional items	EFL201
1.1	Fork dimension	○122*40*920○122*40*1070○122*40*1150○122*40*1220○122*40*1370 ○122*40*1500○122*40*1600○122*40*1700○122*40*1820
1.4	Fork carriage width	●1040mm○Yes and can be customized
1.5	Fork carriage height	●1028mm○Yes and can be customized
2.5	Front wheel material	●Solid○Non-marking solid
2.6	Rear wheel material	●Solid○Non-marking solid
2.7	Battery capacity	●80V150AH○80V205AH○80V280AH
2.8	Charger	●80V35A (integrated) ○80V60A (integrated) ○80V65A○80V130A
2.9	Battery indicator	●With time
2.10	Seat type	●Regular○Premium○Suspension○Suspension+Seatbelt logic switch
2.11	Attachments	●No○Built-in sideshifter○External shifter○Fork positioner
2.13	Traction pin	●Yes
2.14	Electrostatic chain	●Yes
3.1	Foldable fork	●No○Yes and not customized
3.5	Front lamp	●LED
3.6	Rear lamp	●No○LED
3.7	Warning lamp	●Yes
3.8	Steering lamp	●Yes
3.9	Blue lamp	●No○2 front○1 rear○2 front + 1 rear
3.10	Area warning lamp	●No○Red, 1 left + 1 right
3.11	Rearview mirror	●1 rearview mirror○Add rearview mirror on both sides
3.12	Hummer	●Yes
3.17	OPS system	●No○Yes and not customized
3.23	Remote monitoring	●Yes
4.3	Cabin	●No○Basic half cabin○Upgrade half cabin○Full cabin
4.9	Heater	●No○Yes and not customized

Note: ●Standard ○ Optional - Inconformity



tramag

intern transport

☎ +31(0)172 42 42 20

✉ info@tramag.nl

🌐 www.tramag.nl

📍 Harsweg 21
2461 EZ Ter Aar