

# ESL122

## 1200kg Pedestrian Stacker



- Compact duplex mast stacker for light duty application with the advantages of Li-Ion batteries
- Rigid frame and lateral drive for high stability
- Simple design, made with industry-proven components
- Turtle button to operate in narrow spaces
- Fast charging trough integrated charger



Manufacturer			EP
Model designation			ESL122
Drive			Electric
Load capacity	Q	kg	1200
Load center distance	c	mm	600
Service weight		kg	570
Retracted mast height	h1	mm	1856
Lift height	h3	mm	2430
Length to face of forks	l2	mm	563
Overall width	b1/b2	mm	792
Fork dimensions	s/e/l	mm	60/170/1150
Turning radius	Wa	mm	1458
Max. gradeability, laden/unladen		%	3/10
Travel speed, laden/unladen		km/h	4.2/4.5
Lifting speed, laden/unladen		m/s	0.08/0.14
Lowering speed, laden/unladen		m/s	0.1/0.1
Battery voltage/nominal capacity		V/Ah	24/80

## ▣ FEATURES

---

### ■ Strong chassis

The side impact beam, plates, and boxes make the chassis stronger and can greatly reduce stress and deformation caused by heavy load.



### ■ Rigid mast

The rigidity of the mast is greatly improved by its beam structure to provide smooth lifting and stacking for daily operation.



### ■ Easy operation

The extra-long and offset tiller with the crawl speed button provides ESL122 a better visibility and nimble maneuverability when operating in tight space.

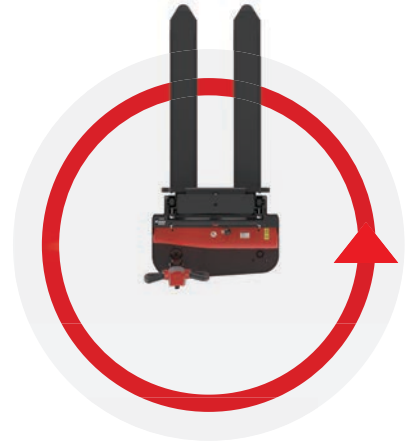

### ■ Efficient hydraulic system

High quality hydraulic pump ensures very little noise, maximum efficiency, durability and shortens lifting time.

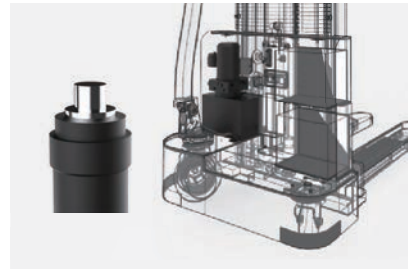

# Electric Stacker 1.2T

## ESL122

Distinguishing mark	1.1	Manufacturer			EP
	1.2	Model designation			ESL122
	1.3	Drive			Electric
	1.4	Operator type			Pedestrian
	1.5	Load capacity	Q	kg	1200
	1.6	Load center distance	c	mm	600
	1.8	Load distance, centre of drive axle to fork	x	mm	798
	1.9	Wheelbase	y	mm	1212
	Service weight	2.1	Service weight		kg
2.2		Axle loading, laden front/rear		kg	650/1120
2.3		Axle loading, unladen front/rear		kg	430/140
Tyres/chassis	3.1	Tyre type			Polyurethane
	3.2.1	Tyre size, front		mm	Ø210x70
	3.3.1	Tyre size, rear		mm	Ø74x72
	3.4	Additional wheels (castor wheels)		mm	Ø130x55
	3.5	Wheels, number front/rear (x=drive wheels)		mm	1x, 1/4
	3.6.1	Tread width, front	b10	mm	531
	3.7.1	Tread width, rear	b11	mm	405
Dimensions	4.0	Max. Lift Height	H	mm	—
	4.2	Retracted mast height	h1	mm	1856
	4.3	Free lift	h2	mm	—
	4.4	Lift height	h3	mm	2430
	4.5	Height, mast extended	h4	mm	3071
	4.6	Initial lift	h5	mm	—
	4.9	Height of tiller handle in drive position min./max.	h14	mm	760/1140
	4.10	Height of wheel arms	h8	mm	—
	4.15	Lowered height	h13	mm	85
	4.19	Overall length	l1	mm	1713
	4.20	Length to face of forks	l2	mm	563
	4.21	Overall width	b1/b2	mm	792
	4.22	Fork dimensions	s/e/l	mm	60/ 170/ 1150
	4.24	Fork carriage width	b3	mm	680
	4.25	Distance between fork-arms	b5	mm	570
	4.26	Distance between wheel arms/loading surfaces	b4	mm	—
	4.31	Ground clearance, laden, below mast	m1	mm	—
	4.32	Ground clearance, center of wheelbase	m2	mm	25
	4.34.1	Aisle width for pallets 1000x1200 crossways	Ast	mm	2290
	4.34.2	Aisle width for pallets 800x1200 crossways	Ast	mm	2225
4.35	Turning radius	Wa	mm	1458	
Performance data	5.1	Travel speed, laden/unladen		km/ h	4.2/4.5
	5.2	Lifting speed, laden/unladen		m/s	0.08/0.14
	5.3	Lowering speed, laden/unladen		m/s	0.10/0.10
	5.8	Max. gradeability, laden/unladen		%	3/10
	5.10	Service brake			Electromagnetic
Electric-engine	6.1	Drive motor rating S2 60 min		kW	0.75
	6.2	Lift motor rating at S3 15%		kW	2.2
	6.4	Battery voltage/nominal capacity		V/Ah	24V/80Ah
	6.5	Battery weight		kg	27.5
	Addition data	8.1	Type of drive control		
10.5		Steering design			Mechanical
10.7		Sound pressure level at the driver's ear		dB(A)	74

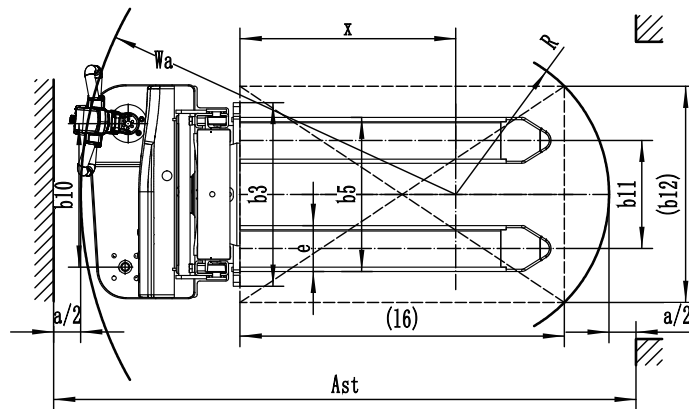
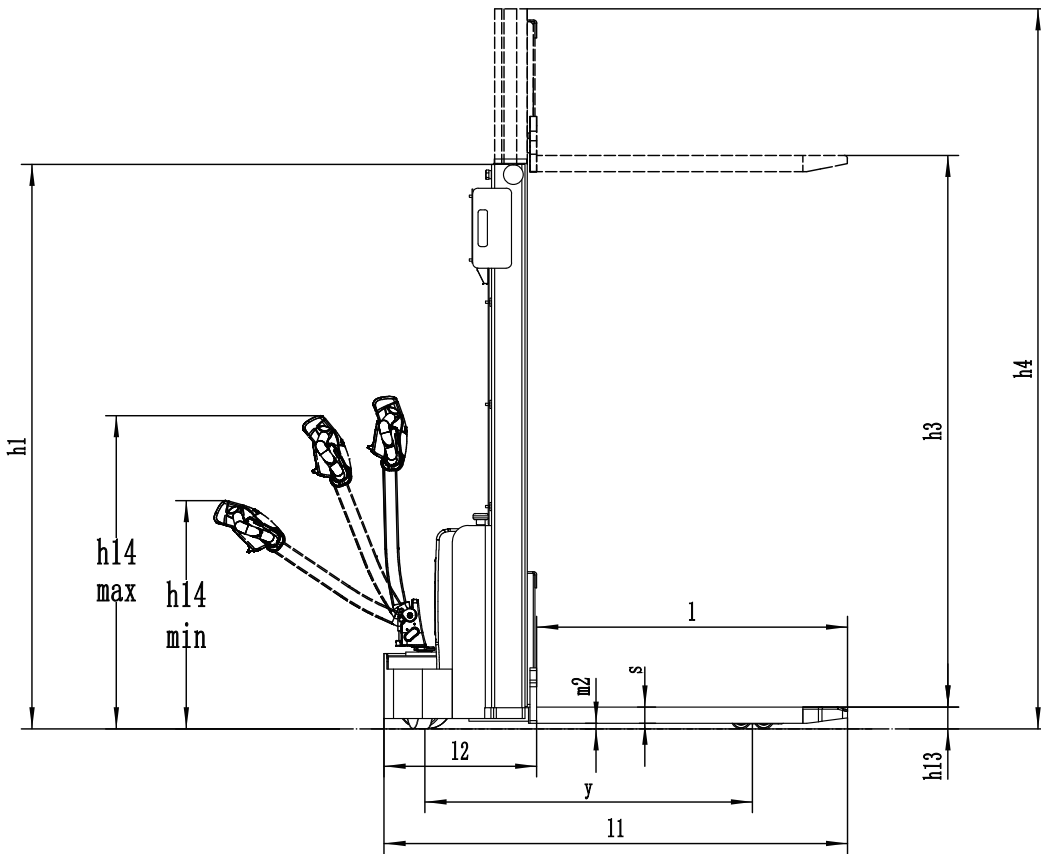

RATDE CAPACITIES GRAPH

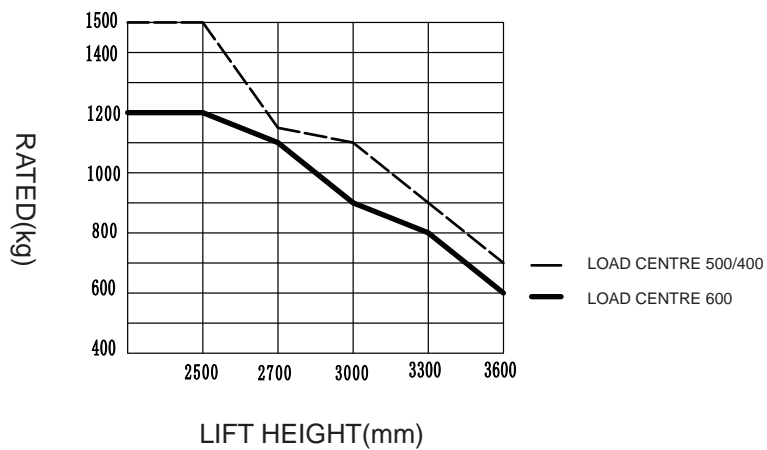

## Mast Option:

Mast types	Lift height h3+h13 (mm)	Height, mast lowered h1 (mm)	Free lift h2 (mm)	Height, mast extended h4 (mm)
2-Standard Mast	2516	1856	—	3071
	2716	1956	—	3271
	3016	2106	—	3571
	3316	2256	—	3871

## Option:

No.	Optional items	ESL122
1.1	Fork length	●1150○1220
1.2	Fork width	●570○685
2.1	Load wheel type	●Double
2.2	Load wheel material	●PU
2.3	Drive wheel material	●PU
2.7	Battery capacity	●80Ah
2.8	Charger	●24V-30A inside
2.9	Battery indicator	●With time
3.3	Castor wheels	●Yes and not customized
3.16	Vertical handler working	●Yes and not customized

Note: ●Standard ○ Optional - Inconformity



# tramag

intern transport

 +31 (0)172 42 42 20

 [info@tramag.nl](mailto:info@tramag.nl)

 [www.tramag.nl](http://www.tramag.nl)

 Harsweg 21  
2461 EZ Ter Aar