



EFL253/303/353(S)

Li-ion counterbalance forklift

2.5/3.0/3.5T **LI-ION**
TECHNOLOGY

- Higher performance for productivity boost
- The truck structure integrates aesthetics and practical design
- Ergonomic improvements for comfortable operation
- Optimized overhead guard for usage of a full cabin
- Lithium technology to replace internal combustion engine



FEATURE

Higher performance for productivity boost

Max travel speed 16/17km/h to cover diverse intralogistics application needs.

Max battery capacity 80V/460Ah and max charging current 200A for longer uptime and fast charging.

Max gradeability 20/25% to deliver better stability on ramps.

Max lifting speed 0.4/0.5m/s for greater efficiency.

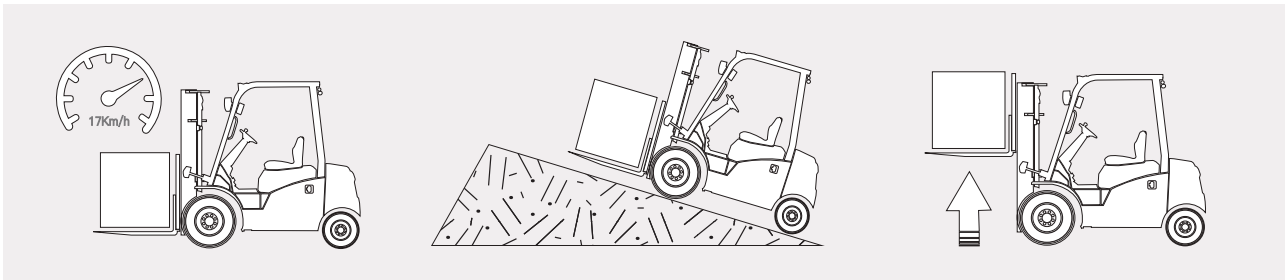

The truck structure integrates aesthetics and practical design

Both practicality and beauty are reflected in the design of the new EFL series. It inherits the robust chassis of the T8 IC truck series and features a more streamlined and compact counterweight, to better fit in confined space. Plus, the rain-proofed charging port protects the port from water splash and ensures charging safety.



Lithium technology to replace internal combustion engine

The lithium technology has proven itself as an emission-free and maintenance-free alternative to diesel. The new generation of EFL series handles loads with consistently high performance due to opportunity charging even for the most demanding applications.



■ Multi-functions for safe operation and easy fleet management

The new EFL series is equipped with a variety of functional configurations, such as OPS system, Telematics and card system, which not only takes security as priority but also reinforce easier fleet management.

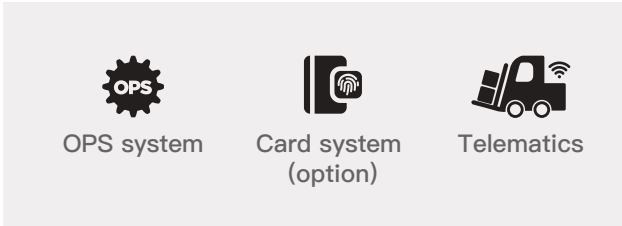

■ Ergonomic improvements for comfortable operation

The workspace of the new EFL series is more spacious with a simplified panel and a comfortable pedal. The series features a new LCD display that clearly shows speed, working hours, battery status, mileage and parking status so the operator can easily grasp the truck conditions just with a glance.



■ Optimized overhead guard for usage of a full cabin

The brand new overhead guard is bolted, instead of welded, to the truck frame and this is more suitable for usage of a full cabin to cope with all weathers. For flexible strategy, it is easy to install or detach a cabin across different trucks.



Li-ion counterbalance forklift 2.5/3.0/3.5T

EFL253/303/353

Distinguishing mark	1.1	Manufacturer			EP	EP	EP
	1.2	Model designation			EFL253	EFL303	EFL353
	1.3	Drive			Electric	Electric	Electric
	1.4	Operator type			Seated	Seated	Seated
	1.5	Load capacity	Q	kg	2500	3000	3500
	1.6	Load center distance	c	mm	500	500	500
	1.8	Load distance, centre of drive axle to fork	x	mm	495	481	486
	1.9	Wheelbase	y	mm	1740	1740	1740
	Service weight	2.1	Service weight			3780	4280
2.2		Axle loading, laden front/rear		kg	5720/560	6595/685	7415/655
2.3		Axle loading, unladen front/rear		kg	1805/1990	1900/2380	1930/2640
Tyres/chassis	3.1	Tyre type			Solid rubber	Solid rubber	Solid rubber
	3.2	Tyre size, front			7.00-12	28X9-15	28X9-15
	3.3	Tyre size, rear			18X7-8	18x7-8	18X7-8
	3.5	Wheels, number front/rear (x=drive wheels)		mm	2x/ 2	2x/ 2	2x/ 2
	3.6	Tread width, front	b10	mm	975	1010	1010
	3.7	Tread width, rear	b11	mm	955	955	955
	Dimensions	4.1	Tilt of mast/fork carriage forward/backward	α/β	°	6/ 10	6/ 10
4.2		Retracted mast height	h1	mm	2090	2070	2070
4.3		Free lift	h2	mm	120	135	135
4.4		Lift height	h3	mm	3000	3000	3000
4.5		Height, mast extended	h4	mm	4025	4095	4095
4.7		Height of overhead guard (cabin)	h6	mm	2165	2180	2180
4.8		Seat height/standing height	h7	mm	1095	1110	1110
4.12		Tow coupling height	h10	mm	330	345	345
4.19		Overall length	l1	mm	3600	3610	3688
4.20		Length to face of forks	l2	mm	2530	2540	2618
4.21		Overall width	b1/b2	mm	1054	1210	1210
4.22		Fork dimensions	s/e/l	mm	40x122x1070	45x122x1070	50x122x1070
4.23		A,B Fork carriage class/type A, B			2A	3A	3A
4.24		Fork carriage width	b3	mm	1040	1100	1100
4.31		Ground clearance, laden, below mast	m1	mm	125	130	130
4.32		Ground clearance, center of wheelbase	m2	mm	170	185	185
4.34.1		Aisle width for pallets 1000x1200 crossways	Ast	mm	4000	4028	4091
4.34.2		Aisle width for pallets 800x1200 lengthways	Ast	mm	4200	4228	4291
4.35		Turning radius	Wa	mm	2305	2347	2405
Performance data		5.1	Travel speed, laden/unladen		km/h	11/12	11/12
	5.2	Lifting speed, laden/unladen		m/s	0.29/0.36	0.29/0.36	0.28/0.36
	5.3	Lowering speed, laden/unladen		m/s	0.43/0.44	0.43/0.44	0.43/0.44
	5.5	Drawbar pull, laden/unladen		N	—	—	—
	5.6	Max. drawbar pull, laden/unladen		N	—	—	—
	5.8	Max. gradeability, laden/unladen		%	15/15	15/15	15/15
	5.10	Service brake			Hydraulic	Hydraulic	Hydraulic
5.11	Parking brake			Mechanical	Mechanical	Mechanical	
Electric-engine	6.1	Drive motor rating S2 60 min		kW	10	10	10
	6.2	Lift motor rating at S3 15%		kW	16	16	16
	6.4	Battery voltage/nominal capacity		V/Ah	80V205AH	80V205AH	80V280AH
	6.5	Battery weight		kg	—	—	—
Additional data	8.1	Type of drive control			AC	AC	AC
	10.5	Steering design			Hydraulic	Hydraulic	Hydraulic
	10.7	Sound pressure level at the driver's ear		dB(A)	< 74	< 74	< 74

If there are improvements of technical parameters or configurations, no further notice will be given.
The diagram shown may contain non-standard configurations.

Li-ion counterbalance forklift 2.5/3.0/3.5T

EFL253S/303S/353S

	Distinguishing mark			EP	EP	EP	
	1.1	Manufacturer					
	1.2	Model designation		EFL253S	EFL303S	EFL353S	
	1.3	Drive		Electric	Electric	Electric	
	1.4	Operator type		Seated	Seated	Seated	
	1.5	Load capacity	Q	kg	2500	3000	3500
	1.6	Load center distance	c	mm	500	500	500
	1.8	Load distance, centre of drive axle to fork	x	mm	495	481	486
	1.9	Wheelbase	y	mm	1740	1740	1740
	2.1	Service weight		kg	3955	4305	4625
	2.2	Axle loading, laden front/rear		kg	5795/660	6575/730	7355/770
	2.3	Axle loading, unladen front/rear		kg	1865/2090	1880/2425	1870/2755
	3.1	Tyre type			Solid rubber	Solid rubber	Solid rubber
	3.2	Tyre size, front			7.00-12	28X9-15	28X9-15-
	3.3	Tyre size, rear			18X7-8	200/50-10	200/50-10
	3.5	Wheels, number front/rear (x=drive wheels)		mm	2x/ 2	2x/ 2	2x/ 2
	3.6	Tread width, front	b10	mm	975	1010	1010
	3.7	Tread width, rear	b11	mm	955	955	955
	4.1	Tilt of mast/fork carriage forward/backward	α/β	°	6/ 10	6/ 10	6/ 10
	4.2	Retracted mast height	h1	mm	2090	2070	2070
	4.3	Free lift	h2	mm	120	135	135
	4.4	Lift height	h3	mm	3000	3000	3000
	4.5	Height, mast extended	h4	mm	4025	4095	4095
	4.7	Height of overhead guard (cabin)	h6	mm	2165	2180	2180
	4.8	Seat height/standing height	h7	mm	1095	1110	1110
	4.12	Tow coupling height	h10	mm	330	345	345
	4.19	Overall length	l1	mm	3600	3610	3688
	4.20	Length to face of forks	l2	mm	2530	2540	2618
	4.21	Overall width	b1/b2	mm	1054	1210	1210
	4.22	Fork dimensions	s/e/l	mm	40×122×1070	45×122×1070	50×122×1070
	4.23	A,B Fork carriage class/type A, B			2A	3A	3A
	4.24	Fork carriage width	b3	mm	1040	1100	1100
	4.31	Ground clearance, laden, below mast	m1	mm	125	130	130
	4.32	Ground clearance, center of wheelbase	m2	mm	170	185	185
	4.34.1	Aisle width for pallets 1000×1200 crossways	Ast	mm	4000	4028	4091
	4.34.2	Aisle width for pallets 800×1200 lengthways	Ast	mm	4200	4228	4291
	4.35	Turning radius	Wa	mm	2305	2347	2405
	5.1	Travel speed, laden/unladen		km/h	16/17	16/17	16/17
	5.2	Lifting speed, laden/unladen		m/s	0.4/0.5	0.4/0.5	0.4/0.5
	5.3	Lowering speed, laden/unladen		m/s	0.43/0.44	0.43/0.44	0.43/0.44
	5.5	Drawbar pull, laden/unladen		N	—	—	—
	5.6	Max. drawbar pull, laden/unladen		N	—	—	—
	5.8	Max. gradeability, laden/unladen		%	20/25	20/25	18/25
	5.10	Service brake			Hydraulic	Hydraulic	Hydraulic
	5.11	Parking brake			Mechanical	Mechanical	Mechanical
	6.1	Drive motor rating S2 60 min		kW	17	17	17
	6.2	Lift motor rating at S3 15%		kW	26	26	26
	6.4	Battery voltage/nominal capacity		V/Ah	80V230AH	80V230AH	80V280AH
	6.5	Battery weight		kg	—	—	—
	8.1	Type of drive control			AC	AC	AC
	10.5	Steering design			Hydraulic	Hydraulic	Hydraulic
	10.7	Sound pressure level at the driver's ear		dB(A)	< 74	< 74	< 74

If there are improvements of technical parameters or configurations, no further notice will be given.
The diagram shown may contain non-standard configurations.

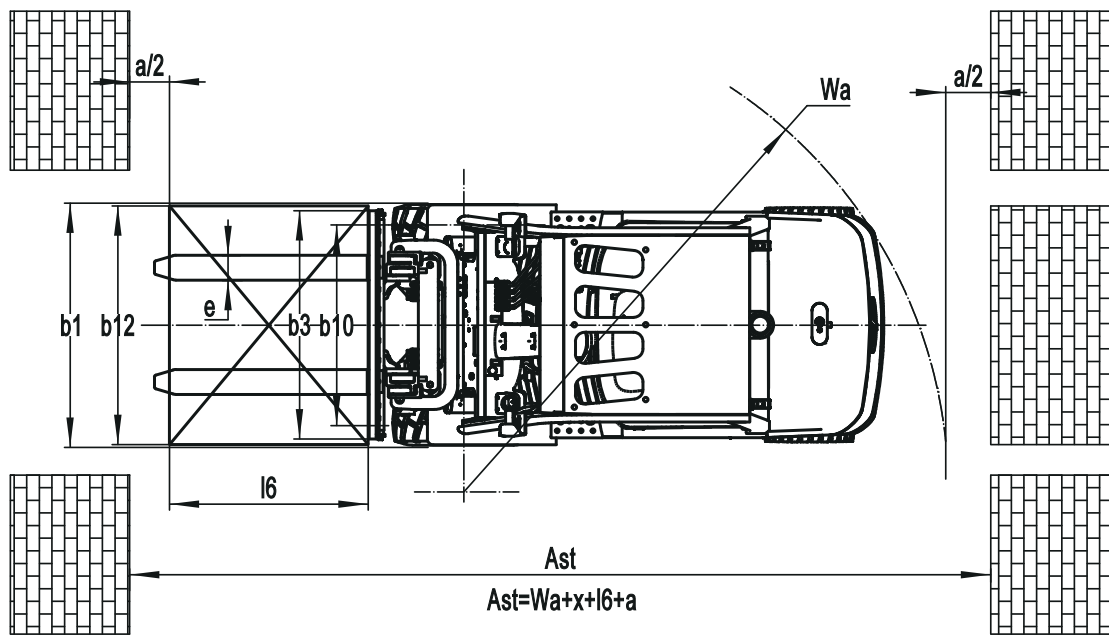
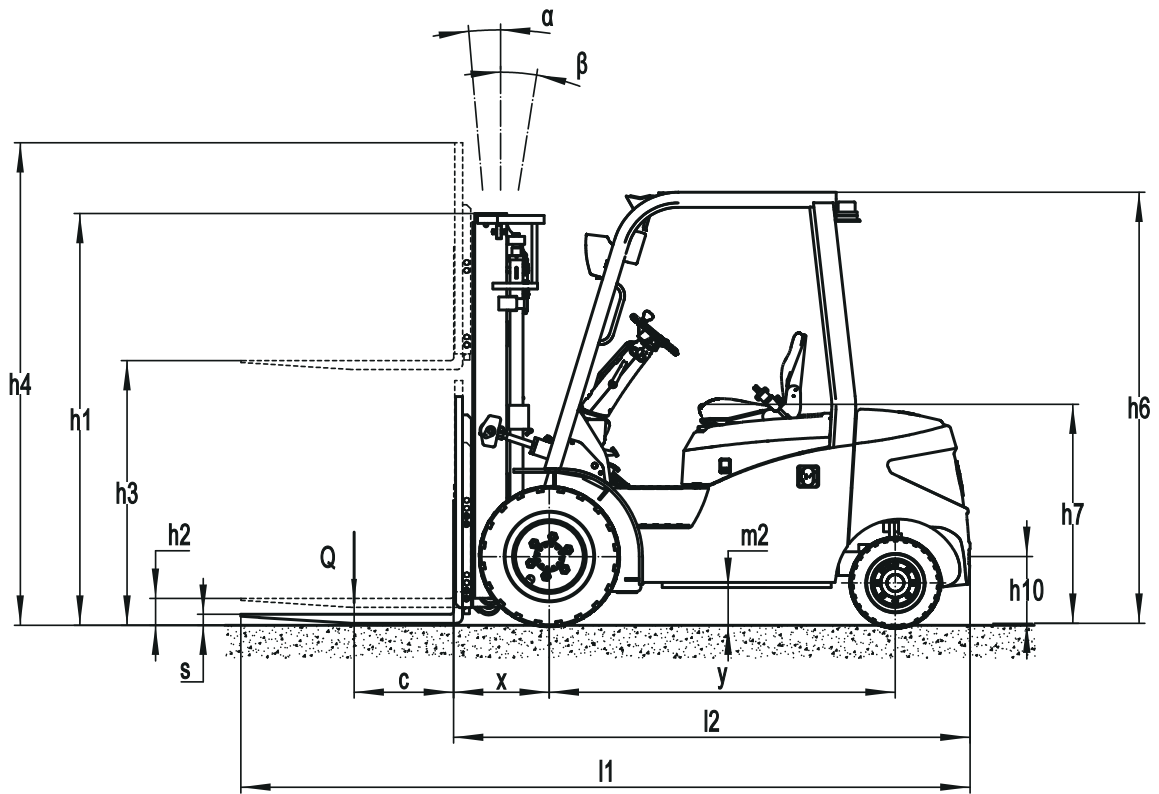

Mast Option

EFL253

	Mast types	Lift height (h3)	Height, Mast			Height, Free lift(h2)		Load distance centre of drive axle to fork X	Tilt of mast/fork carriageforward/backward		Load capacity	
			Height, mast lowered(h1)	Height, mast extended(h4)		No shelving	With shelving		α	β	500mm Load center distance	
				No shelving	With shelving						2.5t	
			mm	mm	mm	mm	mm		mm	mm	Deg	Deg
2-Standard Mast	2W300	3000	2090	3565	4025	120	120	495	6	10	2500	—
	2W330	3300	2240	3865	4325	120	120	495	6	10	2500	—
	2W350	3500	2340	4065	4525	120	120	495	6	10	2400	—
	2W360	3600	2390	4165	4625	120	120	495	6	10	2300	—
	2W400	4000	2640	4565	5025	120	120	495	6	6	2200	—
	2W450	4500	2890	5065	5525	120	120	495	6	6	2050	—
2-Free Mast	2F300	3000	2035	3565	4025	1470	1010	476	6	10	2500	—
	2F330	3300	2185	3865	4325	1620	1160	476	6	10	2500	—
	2F360	3600	2335	4165	4625	1770	1310	476	6	10	2300	—
3-Free Mast	3F430	4300	2035	4865	5325	1470	1010	488	6	6	2200	—
	3F450	4500	2115	5065	5525	1550	1090	488	6	6	2150	—
	3F480	4800	2220	5365	5825	1655	1195	488	6	6	2100	—
	3F500	5000	2305	5565	6025	1740	1280	488	6	6	2000	—
	3F550	5500	2555	6065	6525	1990	1530	488	3	5	1700	—
	3F600	6000	2805	6565	7025	2240	1780	488	3	5	1500	—

EFL303/353

	Mast types	Lift height (h3)	Height, Mast			Height, Free lift(h2)		Load distance centre of drive axle to fork X		Tilt of mast/fork carriageforward/backward		Load capacity		Load capacity	
			Height, mast lowered(h1)	Height, mast extended(h4)		No shelving	With shelving	3.0t	3.5t	α	β	500mm Load center distance		500mm Load center distance	
				No shelving	With shelving							3.0t		3.5t	
			mm	mm	mm	mm	mm	mm	mm	mm	Deg	Deg	kg	kg	kg
2-Standard Mast	2W270	2700	1920	3330	3795	135	135	481	486	6	10	3000	—	3500	—
	2W300	3000	2070	3630	4095	135	135	481	486	6	10	3000	—	3500	—
	2W330	3300	2220	3930	4395	135	135	481	486	6	10	3000	—	3500	—
	2W350	3500	2320	4130	4595	135	135	481	486	6	10	3000	—	3500	—
	2W360	3600	2370	4230	4695	135	135	481	486	6	10	2900	—	3400	—
	2W400	4000	2620	4630	5095	135	135	481	486	6	10	2800	—	3300	—
2-Free Mast	2W450	4500	2870	5130	5595	135	135	481	486	6	6	2600	—	3100	—
	2F300	3000	2040	3630	4095	1410	945	481	486	6	10	3000	—	3500	—
	2F330	3300	2190	3930	4395	1560	1095	481	486	6	10	3000	—	3500	—
3-Free Mast	2F360	3600	2340	4230	4695	1710	1245	481	486	6	10	2900	—	3500	—
	3F430	4300	2040	4930	5395	1410	945	495	500	6	6	2750	—	3300	—
	3F450	4500	2120	5130	5595	1490	1025	495	500	6	6	2700	—	3000	—
	3F480	4800	2190	5430	5895	1560	1095	495	500	6	6	2600	—	2700	—
	3F500	5000	2310	5630	6095	1680	1215	495	500	6	6	2200	—	2600	—
	3F550	5500	2560	6130	6595	1930	1465	495	500	3	5	1900	—	2350	—
	3F600	6000	2810	6630	7095	2180	1715	495	500	3	5	1400	—	1900	—

RATED CAPACITIES

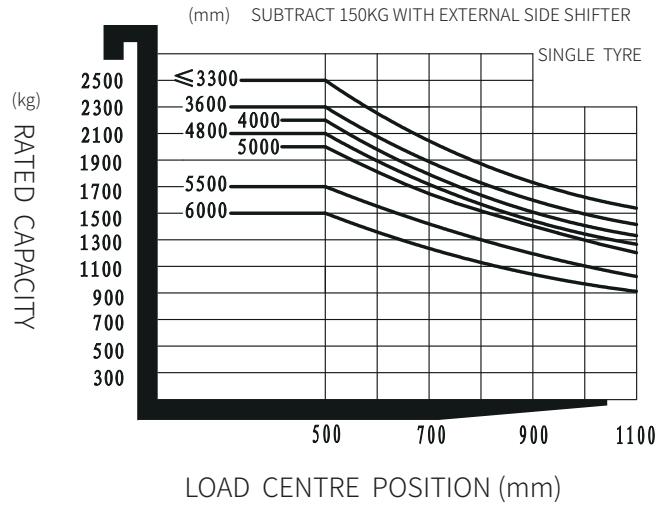

Option

No.	Optional items	EFL253	EFL253S
1.1	Fork dimension	○122*40*920 ○122*40*1070 ○122*40*1150 ○122*40*1220 ○122*40*1370 ○122*40*1500 ○122*40*1600 ○122*40*1700 ○122*40*1820 ○122*40*1900 ○122*40*2000 ○122*40*2200	○122*40*920 ○122*40*1070 ○122*40*1150 ○122*40*1220 ○122*40*1370 ○122*40*1500 ○122*40*1600 ○122*40*1700 ○122*40*1820 ○122*40*1900 ○122*40*2000 ○122*40*2200
1.4	Fork carriage width	●1040mm ○Yes and can be customized	●1040mm ○Yes and can be customized
1.5	Fork carriage height	●1025mm ○Yes and can be customized	●1025mm ○Yes and can be customized
2.5	Front wheel material	○Pneumatic ○Solid ○Non-marking	○Pneumatic ○Solid ○Non-marking
2.6	Rear wheel material	○Pneumatic ○Solid ○Non-marking	○Pneumatic ○Solid ○Non-marking
2.7	Battery capacity	○80V205AH ○80V280AH ○80V410AH	○80V230AH ○80V460AH
2.8	Charger	○80V35A ○80V65A ○80V130A ○80V200A (only for 410Ah battery) ○80V35A (internal) ○80V60A (internal)	○80V35A ○80V65A ○80V130A ○80V200A (only for 460Ah battery)
2.9	Battery indicator	●With time	
2.10	Seat type	○Regular ○Premium ○Suspension ○Suspension + seatbelt logic switch	
2.11	Attachments	●No ○Built-in sideshifter ○External shifter ○Fork positioner	
2.13	Traction pin	●Yes	
3.5	Front lamp	●LED	
3.6	Rear lamp	●No ○LED	
3.7	Warning lamp	●Yes	
3.8	Steering lamp	●Yes	
3.9	Blue lamp	●No ○2 front ○1 rear ○2 front + 1 rear	
3.10	Area warning lamp	●No ○1 left + 1 right (red)	
3.11	Rearview mirror	●1 in the middle ○Add 1 on both sides	
3.12	Buzzer	●Yes	
3.17	OPS system	●Yes	
3.23	Telematics	●Yes and not customized	
4.3	Cabin	●No ○Basic semi-enclosed cabin ○Upgrade semi-enclosed cabin ○Full cabin	
4.9	Heater	●No ○Yes and not customized	
Note: ●Standard ○ Optional - Inconformity			

RATED CAPACITIES

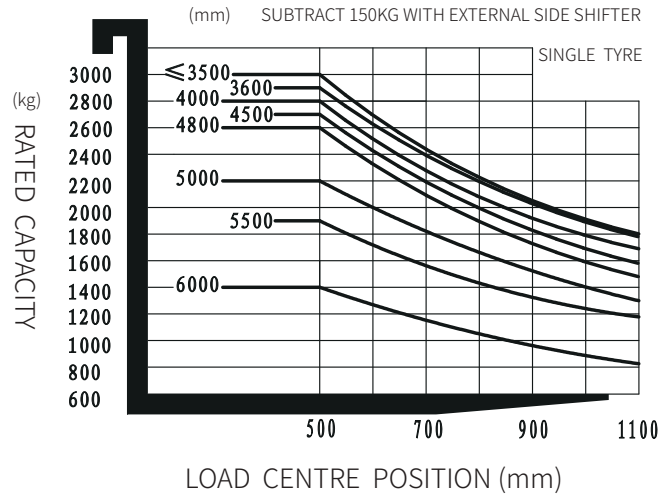

Option

No.	Optional items	EFL303	EFL303(S)
1.1	Fork dimension	○122*45*1070 ○122*45*1150 ○122*45*1220 ○122*45*1370 ○122*45*1520 ○122*45*1600 ○122*45*1700 ○122*45*1820 ○122*45*2000 ○122*45*2200 ○122*45*2400	○122*45*1070 ○122*45*1150 ○122*45*1220 ○122*45*1370 ○122*45*1520 ○122*45*1600 ○122*45*1700 ○122*45*1820 ○122*45*2000 ○122*45*2200 ○122*45*2400
1.4	Fork carriage width	●1100mm ○Yes and can be customized	●1100mm ○Yes and can be customized
1.5	Fork carriage height	●1095mm ○Yes and can be customized	●1095mm ○Yes and can be customized
2.5	Front wheel material	○Pneumati○Solid ○Non-marking	○Pneumati○Solid ○Non-marking
2.6	Rear wheel material	○Pneumati○Solid ○Non-marking	○Pneumati○Solid ○Non-marking
2.7	Battery capacity	○80V205AH○80V280AH○80V410AH	○80V230AH○80V460AH
2.8	Charger	○80V35A○80V65A○80V130A ○80V200A (only for 410Ah battery) ○80V35A (internal)○80V60A (internal)	○80V65A○80V35A○80V130A ○80V200A (only for 460Ah battery)
2.9	Battery indicator	●With time	
2.10	Seat type	○Regular ○Premium ○Suspension ○Suspension + seatbelt logic switch	
2.11	Attachments	●No ○Built-in sideshifter ○External shifter ○Fork positioner	
2.13	Traction pin	●Yes	
3.5	Front lamp	●LED	
3.6	Rear lamp	●No ○LED	
3.7	Warning lamp	●Yes	
3.8	Steering lamp	●Yes	
3.9	Blue lamp	●No○2 front○1 rear○2 front + 1 rear	
3.10	Area warning lamp	●No ○1 left + 1 right (red)	
3.11	Rearview mirror	●1 in the middle ○Add 1 on both sides	
3.12	Buzzer	●Yes	
3.17	OPS system	●Yes	
3.23	Telematics	●Yes and not customized	
4.3	Cabin	●No ○Basic semi-enclosed cabin ○Upgrade semi-enclosed cabin ○Full cabin	
4.9	Heater	●No ○Yes and not customized	

Note: ●Standard ○ Optional - Inconformity

RATED CAPACITIES

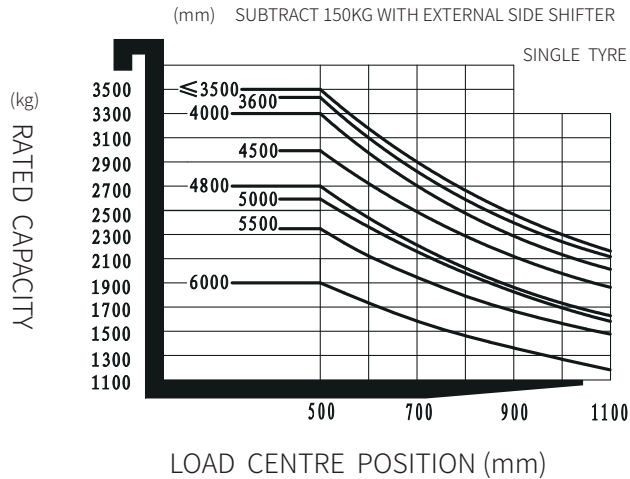

Option

No.	Optional items	EFL353	EFL353(S)
1.1	Fork dimension	○122*50*1070 ○122*50*1150 ○122*50*1220 ○122*50*1370 ○122*50*1520 ○122*50*1600 ○122*50*1700 ○122*50*1820 ○122*50*2000 ○122*50*2200 ○122*50*2420	○122*50*1070 ○122*50*1150 ○122*50*1220 ○122*50*1370 ○122*50*1520 ○122*50*1600 ○122*50*1700 ○122*50*1820 ○122*50*2000 ○122*50*2200 ○122*50*2420
1.4	Fork carriage width	●1100mm ○Yes and can be customized	●1100mm ○Yes and can be customized
1.5	Fork carriage height	●1095mm ○Yes and can be customized	●1095mm ○Yes and can be customized
2.5	Front wheel material	○Pneumatic ○Solid ○Non-marking	○Pneumatic ○Solid ○Non-marking
2.6	Rear wheel material	○Pneumatic ○Solid ○Non-marking	○Pneumatic ○Solid ○Non-marking
2.7	Battery capacity	○80V280AH ○80V410AH	○80V280AH ○80V460AH
2.8	Charger	○80V35A ○80V65A ○80V130A ○80V200A (only for 410Ah battery) ○80V35A (internal) ○80V60A (internal)	○80V65A ○80V35A ○80V130A ○80V200A (only for 460Ah battery)
2.9	Battery indicator		●With time
2.10	Seat type		○Regular ○Premium ○Suspension ○Suspension + seatbelt logic switch
2.11	Attachments		●No ○Built-in sideshifter ○External shifter ○Fork positioner
2.13	Traction pin		●Yes
3.5	Front lamp		●LED
3.6	Rear lamp		●No ○LED
3.7	Warning lamp		●Yes
3.8	Steering lamp		●Yes
3.9	Blue lamp		●No ○2 front ○1 rear ○2 front + 1 rear
3.10	Area warning lamp		●No ○1 left + 1 right (red)
3.11	Rearview mirror		●1 in the middle ○Add 1 on both sides
3.12	Buzzer		●Yes
3.17	OPS system		●Yes
3.23	Telematics		●Yes and not customized
4.3	Cabin		●No ○Basic semi-enclosed cabin ○Upgrade semi-enclosed cabin ○Full cabin
4.9	Heater		●No ○Yes and not customized

Note: ●Standard ○Optional - Inconformity



tramag

intern transport

 +31(0)172 42 42 20

 info@tramag.nl

 www.tramag.nl

 Harsweg 21
2461 EZ Ter Aar