



EFL302/EFL352

Li-Ion Counterbalance Forklift Truck 3.0/3.5T



- IC forklift design with li-ion technology
- Big tyres & high ground clearance
- Simple components for easy service & maintenance
- Li-Ion battery for opportunity charging & flexibility
- Outdoor & indoor: the most flexible forklift in the industry



FEATURE

■ Lithium-ion technology

EFL302/352 adapts LFP Li-ion battery that prevents the battery from self-ignition and ensures safety operation. EFL302/352 supports opportunity charging so it can be charged at preferable time during the day without disrupting working schedules.

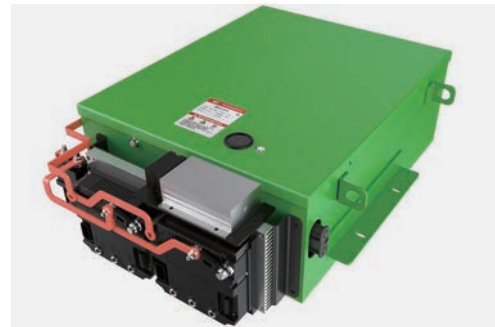

■ Low TCO

Comparing to a diesel forklift truck, EFL302/352 saves 30%-50% of energy cost with li-ion technology. And there is no maintenance fee with no air filter, oil filter, engine oil or starter battery installed on the truck.

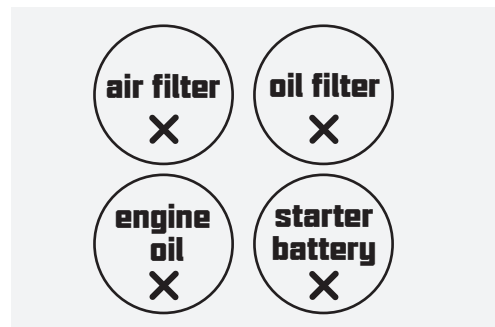

■ Easy driving

The truck is equipped with mechanical braking system. The system shortens the braking distance to ensure safety while reducing the driving fatigue in the meantime.



■ Brilliant visibility

A wide view mast ensures good visibility during operation. This enables operator to better monitor the status of the cargo.



■ Telematics

EFL302/352 offers EP's latest Telematics. It provides the following features to facilitate your fleet management:

- Truck location in real-time
- Reports of truck usages and diagnosis
- Li-ion battery condition analytics
- Updates on card access registration



Electric Counterbalance Forklift Truck 3.0/3.5T

EFL302/EFL352

Distinguishing mark					
1.1	Manufacturer			EP	EP
1.2	Model designation			EFL302	EFL352
1.3	Drive unit			Electrics	Electrics
1.4	Operator type			seated	seated
1.5	rated capacity	Q	kg	3000	3500
1.6	Load center distance	c	mm	500	500
1.8	Load distance, centre of drive axle to fork	x	mm	481	481
1.9	Wheelbase	y	mm	1750	1810
Weight					
2.1	Service weight (include battery)		kg	4080	4560
2.2	Axle loading, laden driving wheels /steering wheels		kg	6420/660	7100/960
2.3	Axle loading, unladen driving wheels /steering wheels		kg	1740/2340	1670/2890
Types,Chassis					
3.1	Tyre type,driving wheels /steering wheels			solid rubber	solid rubber
3.2	Tyre size, driving wheels			28X9-15	28X9-15
3.3	Tyre size, steering wheels			6.50-10	6.50-10
3.5	Wheels, number driving/steering (x=drive wheels)		mm	2x/ 2	2x/ 2
3.6	Tread, Driving wheels	b ₁₀	mm	1010	1010
3.7	Tread, Steering wheels	b ₁₁	mm	980	980
Dimensions					
4.1	Tilt of mast/fork carriage forward/backward	α/ β (°)		6/ 10	6/ 10
4.2	Height, mast lowered	h ₁	mm	2070	2070
4.3	Free lift (load backrest)	h ₂	mm	150	150
4.4	Lift height	h ₃	mm	3000	3000
4.5	Height, mast extended	h ₄	mm	4050	4210
4.7	Height of overhead guard (cabin)	h ₆	mm	2160	2190
4.8	Seat height	h ₇	mm	1130	1130
4.12	Tow center of pin height	h ₁₀	mm	320	320
4.19	Overall length	l ₁	mm	3780	3940
4.20	Length to face of forks	l ₂	mm	2710	2870
4.21	Overall width	b ₁ / b ₂	mm	1230	1230
4.22	Fork dimensions	s/ e/ l	mm	45x125x1070	45x125x1070
4.23	Fork carriage class/type A, B			3A	3A
4.24	Fork carriage width	b ₃	mm	1150	1150
4.31	Ground clearance, laden, below mast	m ₁	mm	120	120
4.32	The minimum ground clearance of frame	m ₂	mm	150	150
4.34.1	Aisle width for pallets 1000 × 1200 crossways	Ast	mm	4181	4326
4.34.2	Aisle width for pallets 800 × 1200 lengthways	Ast	mm	4381	4526
4.35	Turning radius	W _a	mm	2500	2645
Performance data					
5.1	Travel speed, laden/ unladen		km/ h	11/12	11/12
5.2	Lifting speed, laden/ unladen		m/ s	0.29/0.36	0.26/0.34
5.3	Lowering speed, laden/ unladen		m/ s	0.4/0.43	0.4/0.43
5.8	Max. gradeability, laden/unladen		%	15/15	15/15
5.10	Service brake type			Hydraulic / Mechanical	Hydraulic / Mechanical
	park brake type			Mechanical	Mechanical
Electric-engine					
6.1	Drive motor rating S2 60 min		kW	10	10
6.2	Lift motor rating at S3 15%		kW	12	12
6.3	The maximum allowed size battery		mm	731X 608X326	731X 608X326
6.4	Battery voltage/nominal capacity K5			80V205AH	80V280AH
Addition data					
8.1	Type of drive unit			AC	AC
10.5	Steering type			Hydraulic steering	Hydraulic steering
10.7	Sound pressure level at the driver's ear		dB (A)	< 74	< 74

If there are improvements of technical parameters or configurations, no further notice will be given.
The diagram shown may contain non-standard configurations.

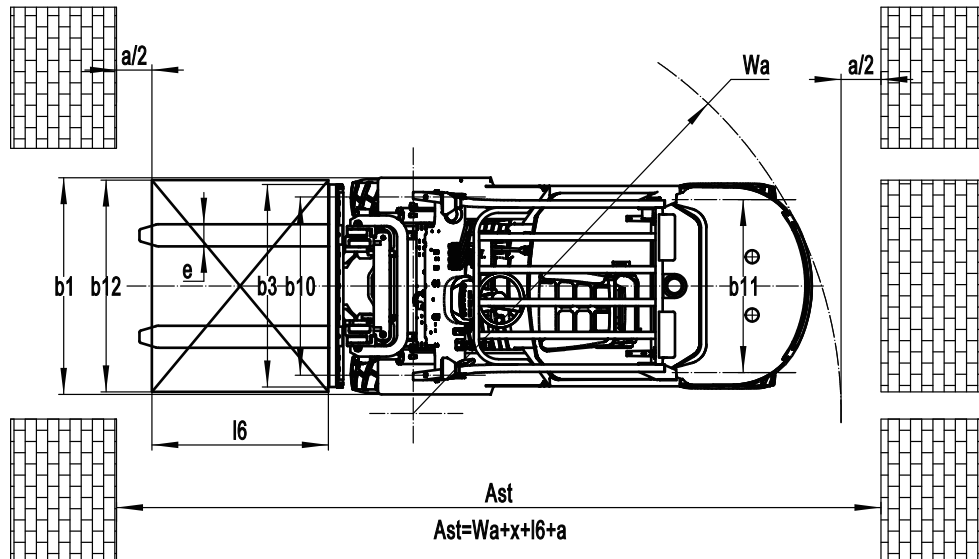
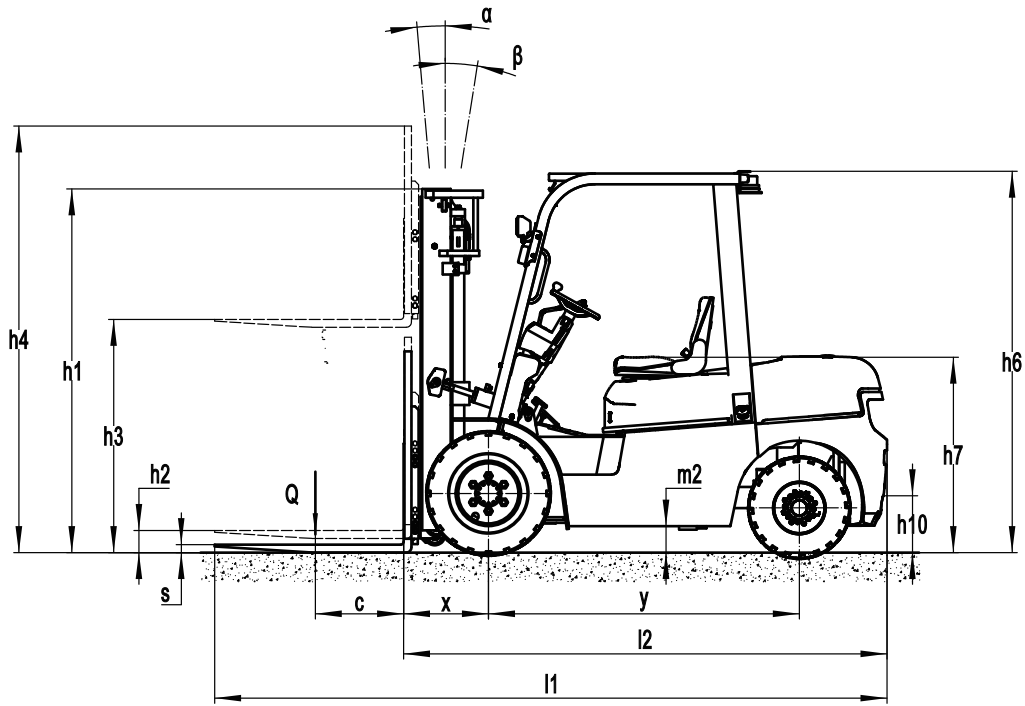

RATED CAPACITIES AND LOAD CENTERES GRAPH

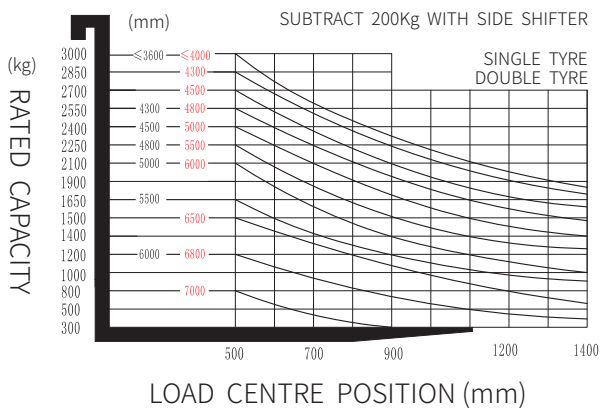

RATED CAPACITIES AND LOAD CENTERES GRAPH

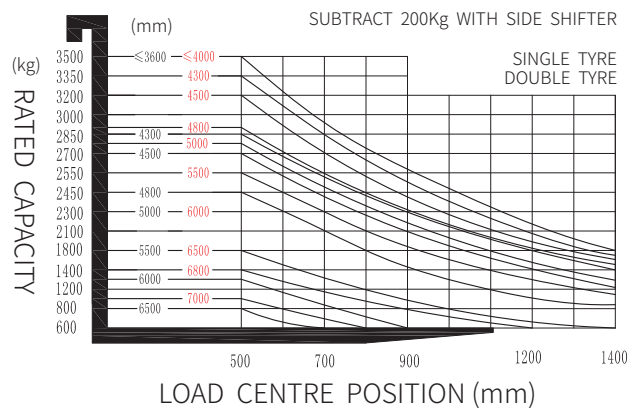

Mast Option

EFL302

Type	Model	Max. fork height	Overall height			Free lift		Front Overhang		Tilt range		Capacity	
			Lowered	Extended		Without backrest	With backrest	3.0t	3.5t	FWD	BWD	Load capacity at 500 mm	
				Without backrest	With backrest							Single tire	Double tire
			mm	mm	mm	mm	mm	mm	Deg	Deg	kg	kg	
Wide view mast	2W200	2000	1570	2570	3110	120	120	481	486	6	10	3000	3000
	2W250	2500	1820	3070	3610	120	120	481	486	6	10	3000	3000
	2W270	2700	1920	3270	3810	120	120	481	486	6	10	3000	3000
	2W300	3000	2070	3570	4110	120	120	481	486	6	10	3000	3000
	2W330	3300	2220	3690	4410	120	120	481	486	6	10	3000	3000
	2W350	3500	2320	3890	4610	120	120	481	486	6	10	3000	3000
	2W360	3600	2370	3990	4710	120	120	481	486	6	10	3000	3000
	2W400	4000	2620	4040	5110	120	120	481	486	6	10	2850	3000
	2W430	4300	2770	4340	5410	120	120	481	486	6	6	2700	2900
2W450	4500	2870	4290	5610	120	120	481	486	6	6	2550	2850	
wide view full 2-stage mast	2F250	2500	1805	2220	3610	1210	560	481	486	6	10	3000	3000
	2F270	2700	1905	2320	3810	1310	660	481	486	6	10	3000	3000
	2F300	3000	2055	2620	4110	1460	810	481	486	6	10	3000	3000
	2F330	3300	2205	3870	4410	1610	960	481	486	6	10	3000	3000
	2F360	3600	2355	4020	4710	1760	1110	481	486	6	10	3000	3000
	2F400	4000	2605	4420	5110	2060	1410	481	486	6	10	2850	3000
wide view full 3-stage mast	3F430	4300	2095	4910	5410	1360	730	495	500	6	6	2550	2850
	3F450	4500	2175	5070	5610	1460	810	495	500	6	6	2400	2700
	3F480	4800	2280	5375	5910	1565	915	495	500	6	6	2250	2550
	3F500	5000	2365	5570	6110	1610	960	495	500	3	6	1650	2250
	3F550	5500	2615	6150	6610	1770	1120	495	500	3	3	1800	2250
	3F600	6000	2865	6570	7110	2020	1370	495	500	3	3	1200	2100

EFL352

Type	Model	Max. fork height	Overall height			Free lift		Front Overhang		Tilt range		Capacity			
			Lowered	Extended		Without backrest	With backrest	3.0t	3.5t	FWD	BWD	Load capacity at 500 mm			
				Without backrest	With backrest							Single tire	Double tire	Single tire	Double tire
			mm	mm	mm	mm	mm	mm	mm	mm	Deg	Deg	kg	kg	kg
Wide view mast	2W200	2000	1570	2570	3110	120	120	481	486	6	10	3000	3000	3500	3500
	2W250	2500	1820	3070	3610	120	120	481	486	6	10	3000	3000	3500	3500
	2W270	2700	1920	3270	3810	120	120	481	486	6	10	3000	3000	3500	3500
	2W300	3000	2070	3570	4110	120	120	481	486	6	10	3000	3000	3500	3500
	2W330	3300	2220	3690	4410	120	120	481	486	6	10	3000	3000	3500	3500
	2W350	3500	2320	3890	4610	120	120	481	486	6	10	3000	3000	3500	3500
	2W360	3600	2370	3990	4710	120	120	481	486	6	10	3000	3000	3500	3500
	2W400	4000	2620	4040	5110	120	120	481	486	6	10	2850	3000	3320	3500
	2W430	4300	2770	4340	5410	120	120	481	486	6	6	2700	2900	2850	3350
2W450	4500	2870	4290	5610	120	120	481	486	6	6	2550	2850	2600	3200	
wide view full 2-stage mast	2F250	2500	1805	2220	3610	1210	560	481	486	6	10	3000	3000	3500	3500
	2F270	2700	1905	2320	3810	1310	660	481	486	6	10	3000	3000	3500	3500
	2F300	3000	2055	2620	4110	1460	810	481	486	6	10	3000	3000	3500	3500
	2F330	3300	2205	3870	4410	1610	960	481	486	6	10	3000	3000	3500	3500
	2F360	3600	2355	4020	4710	1760	1110	481	486	6	10	3000	3000	3500	3500
	2F400	4000	2605	4420	5110	2060	1410	481	486	6	10	2850	3000	2920	3500
wide view full 3-stage mast	3F430	4300	2095	4910	5410	1360	730	495	500	6	6	2550	2850	2850	3350
	3F450	4500	2175	5070	5610	1460	810	495	500	6	6	2400	2700	2700	3200
	3F480	4800	2280	5375	5910	1565	915	495	500	6	6	2250	2550	2450	2900
	3F500	5000	2365	5570	6110	1610	960	495	500	3	6	1650	2250	2300	2750
	3F550	5500	2615	6150	6610	1770	1120	495	500	3	3	1800	2250	1800	2550
	3F600	6000	2865	6570	7110	2020	1370	495	500	3	3	1200	2100	1300	2300

Option

Optional items		EFL302	EFL352
1	Fork length	●1070○customization consultation	●1070○customization consultation
2	Attachments	●NA○integrated side shifter○external side shifter ○ customization consultation	●NA○integrated side shifter○external side shifter ○ customization consultation
3	Overhead guard	●normal overhead guard ○customization consultation	●normal overhead guard ○customization consultation
4	Front wheel	●single○dual	●single○dual
5	Tyre type	●Solid rubber tire ○Environmental solid tire	●Solid rubber tire ○Environmental solid tire
6	Front light	●LED front light	●Front light○LED front light
7	Auxiliary light	●NA○Back light	●NA○Back light
8	Safety	●NA○Fire extinguisher○blue light	●NA○Fire extinguisher○blue light
9	Seat	●normal seat○suspension seat	●normal seat○suspension seat
10	Cockpit	●NA○Cockpit○With fan heater○With front windshield wiper○With rear windshield wiper	●NA○Cockpit○With fan heater○With front windshield wiper○With rear windshield wiper
11	Rearview	●single○dual	●single○dual
12	Air fan	●NA○single	●NA○single
13	Charging	●80V65A○80V100A	●80V65A○80V100A
14	Li-Ion battery	●80V205AH○80V280AH	-



tramag

intern transport

 +31 (0)172 42 42 20

 info@tramag.nl

 www.tramag.nl

 Harsweg 21
2461 EZ Ter Aar